



THT International Co., Ltd

No 11, Alley 259/9, Vong str., Hai Ba Trung District, Ha Noi

Phone : 84 43 8697855; Fax : 84 43 6283741

Email: info@lightconcrete.net; Website: lightconcrete.net

Foam concrete pump

These mobile peristaltic or hose pumps are equipped with more powerful electrical motors than other on the market, allowing it to pump the lightweight foam concrete at full capacity without interruption to long distance and high height. It is an excellent product for specific applications of cast-in-situ houses, roof heating isolation, floor screeding and levelling, underground void filling, etc



Peristaltic pump for foam concrete



Clc pump and mobile mixer

Technical specifications

Model	Max. Capacity	Max Pressure	Hose ID	Hose OD	Hose Length	Rev	Motor power
	L/hour	MPa	mm	mm	mm	r/min	kw
THT-50	5,500	1.5	51	84	1680	35	7.5
THT-65	12,000	1.5	64	100	1750	45	11

Note: The above technical parameters were determined against the medium of clear water under the environment temperature 20°C.

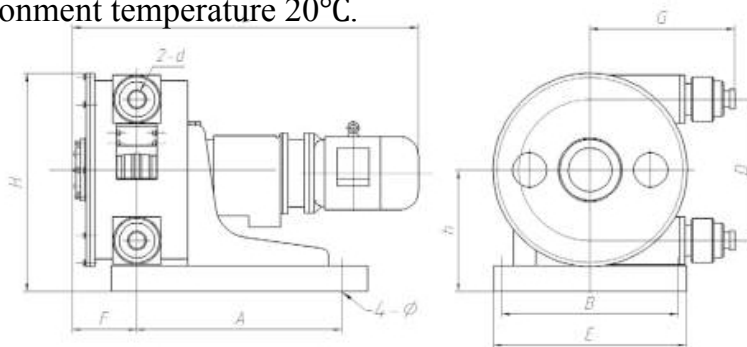

Dimensions:

Model	A	B	D	E	F	G	H	L	h	2-d	4-φ
	mm	mm	mm	mm	mm	mm	mm	mm	mm	mm	mm
THT-50	700	690	635	750	220	540	800	1150	420	51	18
THT-65	800	690	580	750	220	540	800	1195	420	65	18